

Note: Part numbers and standards' values may change. Consult LECO for the latest information.

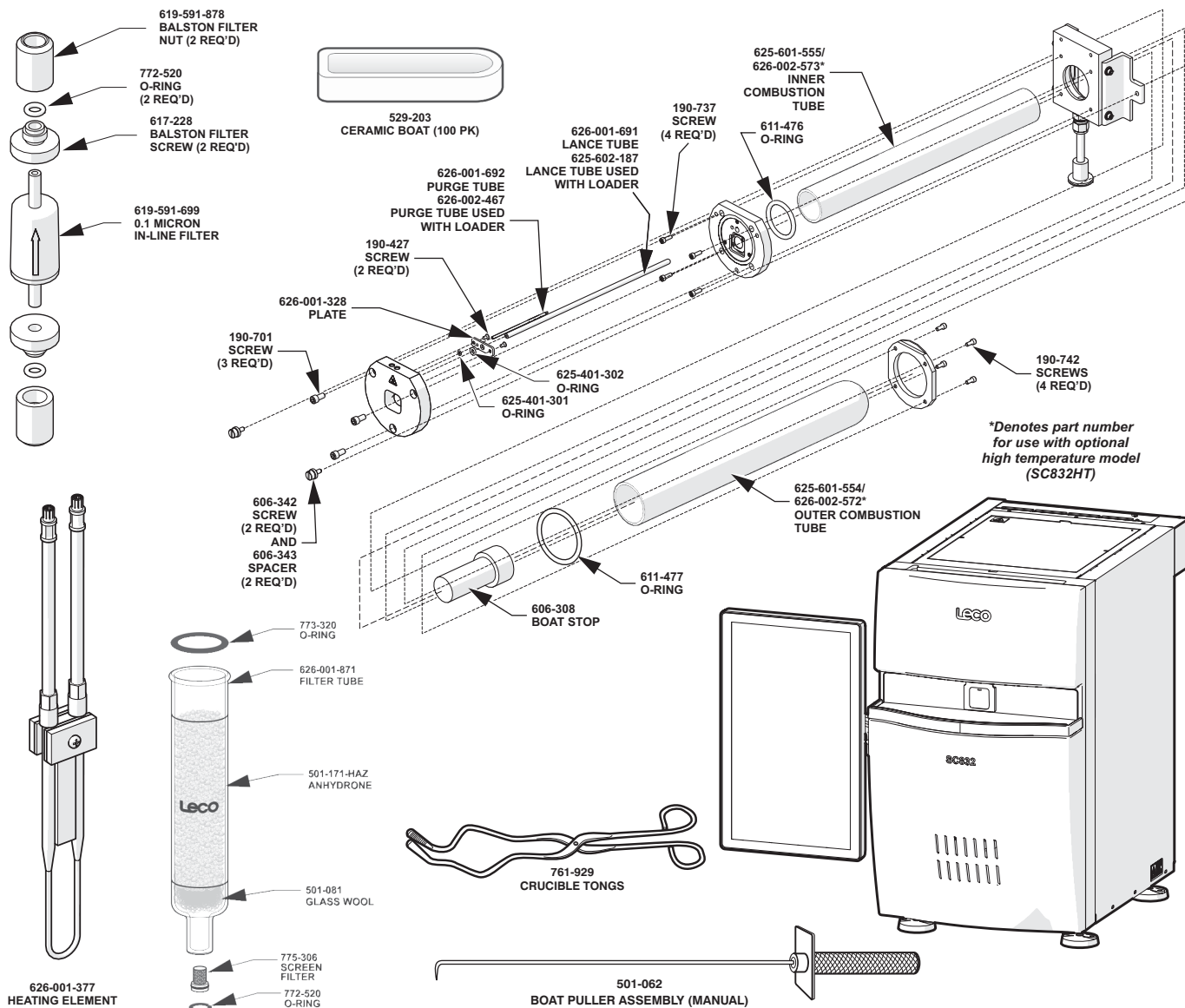

GENERAL COMBUSTION SUPPLIES

- 501-171-HAZ Anhydrene 10-16 Mesh 1 lb.
- 501-426 COM-AID Solids and Powders 1 lb.
- 501-427 Com-Aid Liquids 1 lb.
- 502-321 Accelerator COM-CAT 250 g
- 529-203 Boat Combustion Zp P 100/package
- 528-203-250 Boat Crucible Zir 250/package
- 501-081 Wool Glass 1 lb.
- 763-265 Wool Glass 0.50 lb.
- 502-301 Tungsten Trioxide 125 g
- 769-608-HAZ Metal Trap Antimony 200 g, Used in Halogen Scrubber Packing
- 769-610 F-CL Absrb -8 +20 mesh 225 g, Used in Halogen Scrubber Packing

COMBUSTION TUBES, GLASSWARE, and HEATING ELEMENT

- 606-308 Stop Ceramic Stepped
- 626-001-691 Tube Lance Manual Load, Requires 625-401-302 O-Ring
- 626-001-692 Tube Purge Sst Manual, Requires 625-401-301 O-Ring
- 625-601-554 Tube Combustion Outer, Requires 611-477 O-Ring
- 625-601-555 Tube Combustion Inner, Requires 611-476 O-Ring
- 626-002-572 High Temperature Outer Combustion Tube
- 626-002-573 High Temperature Inner Combustion Tube
- 626-001-377 Heating Element Assy W/Clamp
- 626-001-871 Tube Boros Reagent 1.38 OD 7.0
- 626-001-750 Pack O-Ring Spare SC/C/S832
Contains: (8) 772-520 O-Ring 108 (.250x .436x.093v); (4) 773-320 O-Ring 121 1.062x 1.248x.093v; (2) 611-476 O-Ring 326 (1.625x 1.999x.187a); (2) 611-477 O-Ring 330 (2.125x 2.499x.187a); (2) 625-401-301 O-Ring 006 (.114x .184x.070a); (2) 625-401-302 O-Ring 107 (.206x .309x.103a)

See reverse side for contact information

OPERATION ACCESSORIES

501-062	Assy Boat Puller
761-929	Tong Crucible
501-614	Spatula Sample
503-032	Scoop Glass Accelerator Small
619-591-699	Filter In-Line 0.1 Micron Disposable*
502-007	Cleaner Tube 8 mm x 4 ft
501-241	Lub Grease Vacuum 5.3 oz
502-023	Funnel Quick Disc Tube
776-978	Scoop Glass 1.5 ml, Large
619-592-403	Kit Regulator Oxygen CGA 540
751-350-110	Kit Balance 4-plc Secura 124-1s
611-844	Spatula Flat Spoon Sst
626-002-251	Kit Pump Rebuild

REFERENCE MATERIALS

LECO Corporation is A2LA accredited in accordance with International Standards Organization ISO/IEC 17025:2005 (Certificate No. 3285.01) and Guide 34:2009 (Certificate No. 3285.02) as a reference material producer. Guide 34:2009 products are designated with a ▲ in the following tables.

Pure Chemical Standards

Part No.	Description	% C	% S	Contents
501-034 ▲	Calcium Carbonate	12.0	—	50 g
502-085 ▲	Zinc Sulfide	—	32.91	50 g
502-207 ▲	Cystine	29.99	26.69	5 g
502-298 ▲	Sulfamethazine	51.78	11.52	25 g
502-634 ▲	High Purity Graphite Powder	100%	—	50 g
502-654 ▲	BBOT	72.5	7.4	25 g

Synthetic Carbon Standards

Part No.	Description	% C	Contents
502-632 ▲	Synthetic Carbon	0.1–0.2	50 g
502-630 ▲	Synthetic Carbon	0.40–0.60	50 g
502-029 ▲	Synthetic Carbon	0.90–1.10	50 g
502-030 ▲	Synthetic Carbon	4.90–5.10	50 g

Natural Matrix Standards

Part No.	Description	% C	% S	Contents
502-082 ▲	Tobacco Leaves	35.0–47.0	0.3–0.8	20 g
502-272 ▲	Corn Gluten	51.0–53.0	0.75–1.0	50 g
502-055 ▲	Orchard Leaves	44.0–52.0	2.0–2.8	20 g

Coal and Coke Prox Plus Reference Materials

Part No.	Description	% Sulfur	% Volatile	% Ash	% C	% H	% N	BTU/lb.*	Contents
502-680 ▲	Coal Prox Plus Low	~0.3	~17.0	~11.0	~81.0	~4.0	~1.0	~13893	50 g
502-681 ▲	Coal Prox Plus Med.	~1.3	~32.0	~9.0	~78.0	~5.0	~1.5	~13892	50 g
502-682 ▲	Coal Prox Plus High	~0.5	~41.0	~6.0	~75.0	~5.0	~1.5	~13019	50 g
502-683 ▲	Met Coke Prox Plus	~0.75	~1.0	~10.0	~87.0	~0.3	~1.0	~12718	50 g
502-684 ▲	Pet Coke Prox Plus	~5.5	~13.4	~0.3	~87.0	~3.6	~1.5	~15367	50 g

*for information purposes only

QAR Certified Reference Materials

Part No.	Description	% S	% Volatile	% Ash	% C	% H	% N	BTU/lb.	Contents
502-831	QAR CRM Coal 1	1.5	35.2*	6.9	74.6*	4.8	1.7	13093*	50 g
502-832	QAR CRM Coal 2	0.25	36*	13.0	70.0*	4.0	0.9	11771*	50 g
502-833	QAR CRM Coal 3	0.34	16.5*	10.9	81.0*	4.01	1.1	13862*	50 g
502-834	QAR CRM Coal 4	0.30	34.9*	12.5	68.5*	4.3	0.9	11661*	50 g
502-835	QAR CRM Coal 5	0.5	39.0*	10.5	68.5*	5.0	1.7	12000*	50 g
502-836	QAR CRM Coal 6	3.99	39.2*	12.6	70.2*	4.9	1.3	12604*	50 g
502-837	QAR CRM Coal 7	3.26	38.4*	9.0	72.6*	4.9	1.4	12918*	50 g
502-838	QAR CRM Coal 8	0.70	40.6*	12.1	68.5*	4.9	1.2	12000*	50 g
502-839	QAR CRM Coal 9	2.1	37.7*	7.6	77.5*	5.1	1.5	13833*	50 g
502-845	QAR CRM Coal 10	0.67	3.8*	8.02	87.3*	1.8	0.88	13573*	50 g
502-846	QAR CRM Coal 11	0.70	5.8*	12.2	81.9*	2.4	1.1	13197*	50 g

*For information purposes only

Soil and Ore Standards

Part No.	Description	% C	% S	Contents
502-635	Ore	~0.55	~45	25 g
502-062 ▲	Soil	0.75–1.25	0.015–0.3	65 g
502-308 ▲	Soil	2.5–3.5	0.015–0.3	65 g
502-309 ▲	Soil	10.0–14.0	0.015–0.3	65 g
502-814	Soil	20.0–35.0	0.1–0.5	25 g
502-318 ▲	Ore	≤2	≤2	25 g
502-319 ▲	Ore	1–5	1–5	25 g
502-320 ▲	Ore	2–6	2–6	25 g

Coal Sulfur Only Reference Materials

Part No.	Description	% Sulfur	Contents
502-670 ▲	Coal	~0.5	50 g
502-671 ▲	Coal	~1.0	50 g
502-672	Coal	~2.0	50 g
502-673 ▲	Coal	~3.0	50 g
502-674 ▲	Coal	~5.0	50 g

Ash Reference Materials

Part No.	Description	% S	% C	Contents
502-813 ▲	LECO Fly Ash	~1.0	~1.0	20 g
502-843	Fly Ash Carbon Concentrate	~0.29	~42.0	20 g

Oil and Fuel Calibration Material

Part No.	Description	% S	Contents
502-848	Residual Fuel Oil ~0.25% Sulfur	~0.25	100 ml
502-849 ▲	Residual Fuel Oil ~1% Sulfur	~1	100 ml
502-850	Residual Fuel Oil ~3% Sulfur	~3	100 ml
502-851	White Mineral Oil ~0.01% Sulfur	~0.01	100 ml
502-852	White Mineral Oil ~0.1% Sulfur	~0.1	100 ml
502-853	White Mineral Oil ~1% Sulfur	~1	100 ml
502-854	White Mineral Oil ~5% Sulfur	~5	100 ml

NOTES: Part numbers and standards' values may change. Consult LECO for latest information.

United States: 800-292-6141 • Canada: 800-268-0215 • Other Countries: 269-985-5496
info@leco.com • www.leco.com • ISO-9001:2008 HQ-Q-994 • © 2017 LECO Corporation